



GroupGets LLC

Boson Enclosure User Guide

For TELEDYNE FLIR Boson®

June 2026 - Revision 1

Description

This enclosure is designed to protect the FLIR Boson and easily mount to a tripod. It is designed to work with the FLIR Boson VPC kit and a wide variety of Boson models.

Features

- 1/4x20 thread for mounting
- Aluminum and polyamide body
- Silicon LWIR window 1.25" Ø
- Cable pass-through grommet

Compatibility

- Boson 320 with 2.3-18mm lens
- Boson 640 with 8.7-24mm lens
- FLIR Boson USB VPC kit - **421-0061-00**
- FLIR Boson USB/analog VPC kit - **421-0062-00**



Important Notes

- A desiccant packet can keep the humidity low inside the enclosure to ensure condensation does not form. Desiccant packets can also release humidity as they become saturated. If humidity levels rise above 40% inside the enclosure, changing the desiccant is recommended.
- If the enclosure is frequently opened and closed, the bore seal O-rings should periodically be cleaned and lubricated with silicone-based grease to maintain a good seal.
- Water may enter through the cable grommet if not properly sealed around the cable. Adding dielectric grease can reduce the chance of a leak. For use with the USB/analog VPC kit or multiple cables, the round split-ring can be replaced with an oval split ring.
- The enclosure window will affect radiometric measurements and should be calibrated to maintain measurement accuracy. See the appendix for window transmission data.

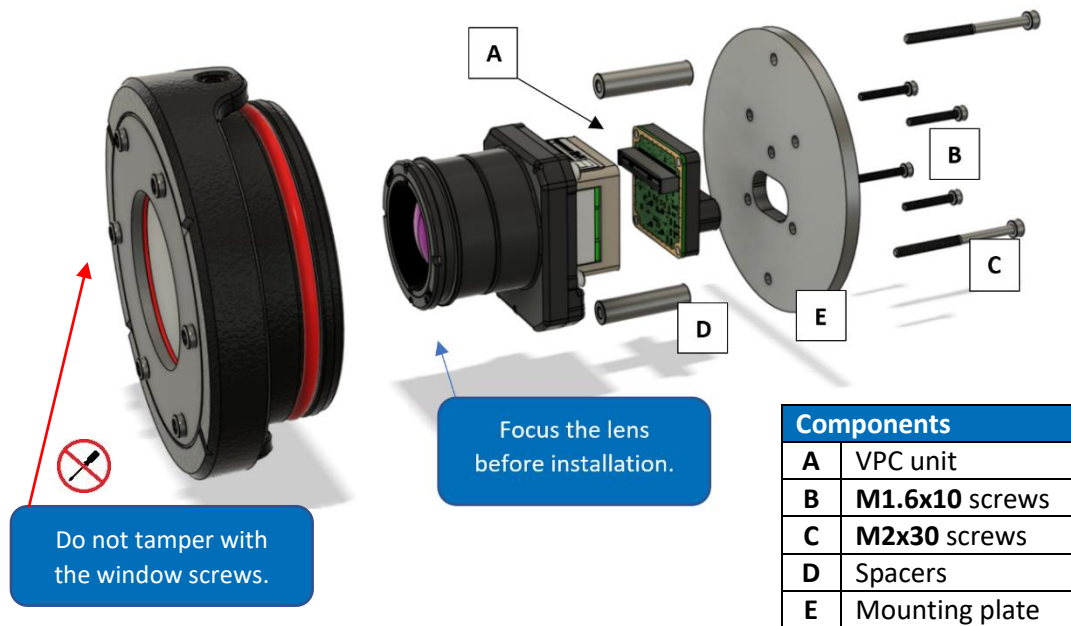

Boson Installation

Opening the enclosure

To remove the front and rear plugs, remove the four **M3x6** screws as shown below.

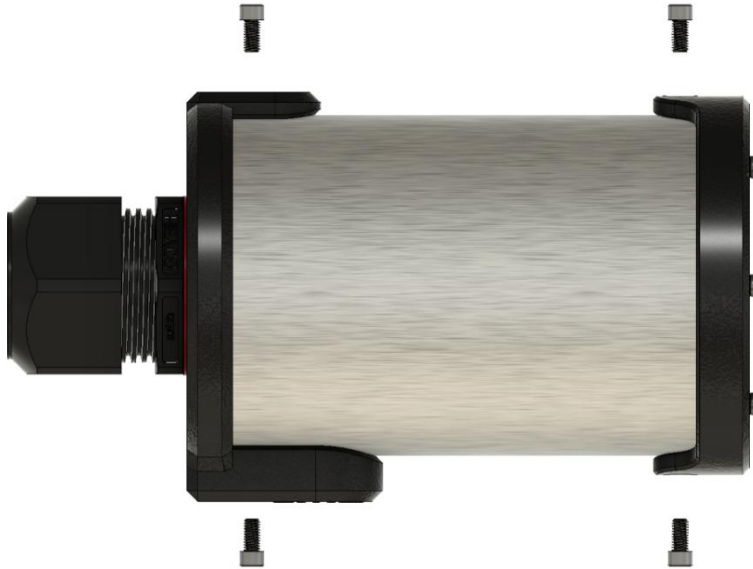

The bore seal gaskets are lubricated with silicone based oil.

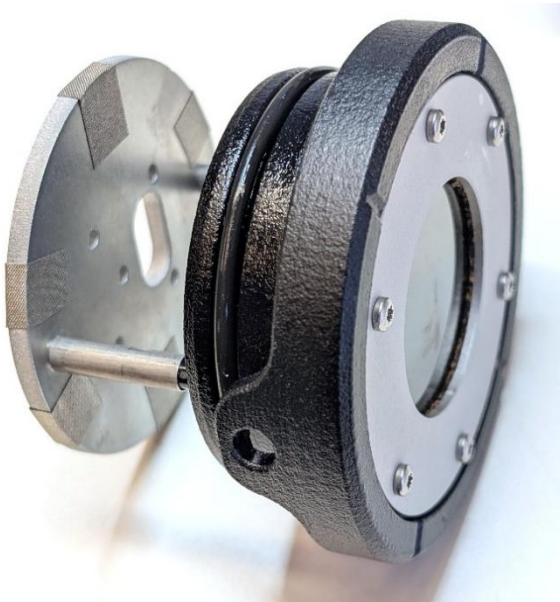

Cable pass-through

1. Remove the grommet nut from the rear plug and use a blunt object to force the rubber split-ring seal out through the plastic spines from the inside.
2. Feed a USB cable through the split-ring grommet and rear plug assembly.
3. Reinsert rubber split-ring grommet the same way it was removed, chamfered side facing out.
4. Thread on the grommet nut back on. Wait to tighten so the cable can be adjusted as necessary before sealing.

	Min	Max
Cable Diameter:	5.5mm	13.5mm
* Verify cables are functional before installing. Do not use cables with fabric sheathing.		

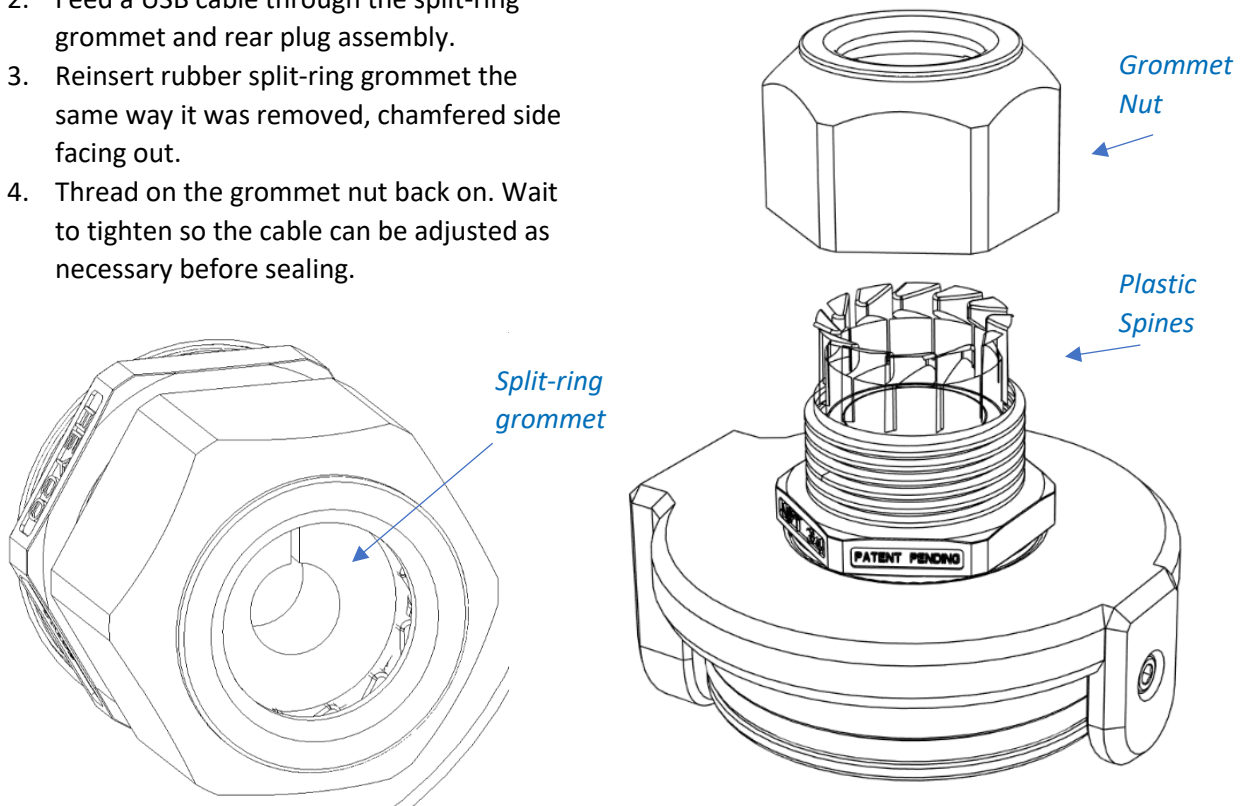

If the Analog VPC kit is used, an alternate split-ring grommet with an oval opening is required.

Mounting the Boson

The process for mounting the Boson in the enclosure will vary by camera model. Cameras with wider FOV need to be closer to the window. Some models can be mounted to the rear rather than the front.

Use the table and figures below to determine which of the 3 configurations work with your Boson model. Additional spacers and screws are included for custom configurations.

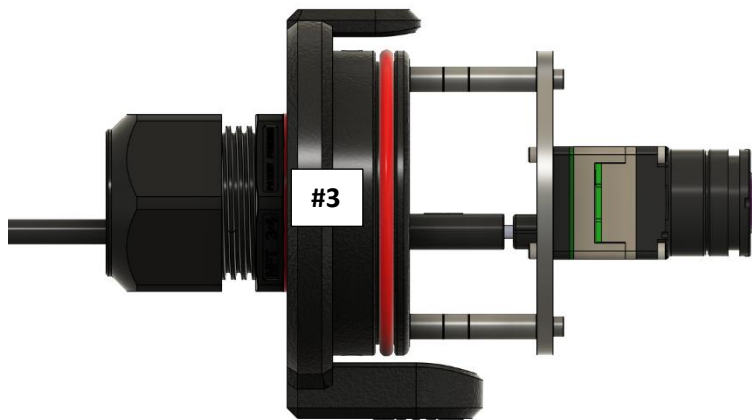
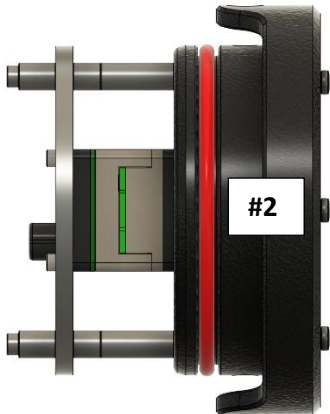
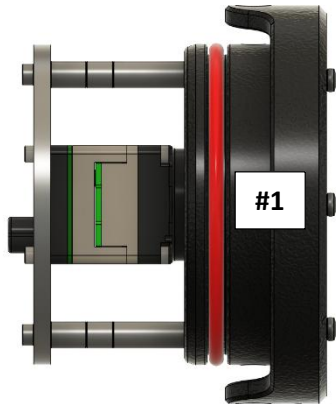

Focal Length 320 Series	HFOV	Recommended Configuration
2.3mm	92°	#2
4.3mm	50°	
4.5mm		#1 or #3
6.3mm	34°	
9.1mm	24°	
13.8mm	16°	
18mm	12°	
Focal Length 640 Series	HFOV	Recommended Configuration
8.7mm	50°	#3
9.2mm		#1 or #3
13.6mm	32°	
14mm		
18mm	24.3°	
24mm	18°	#3

Window Transmission

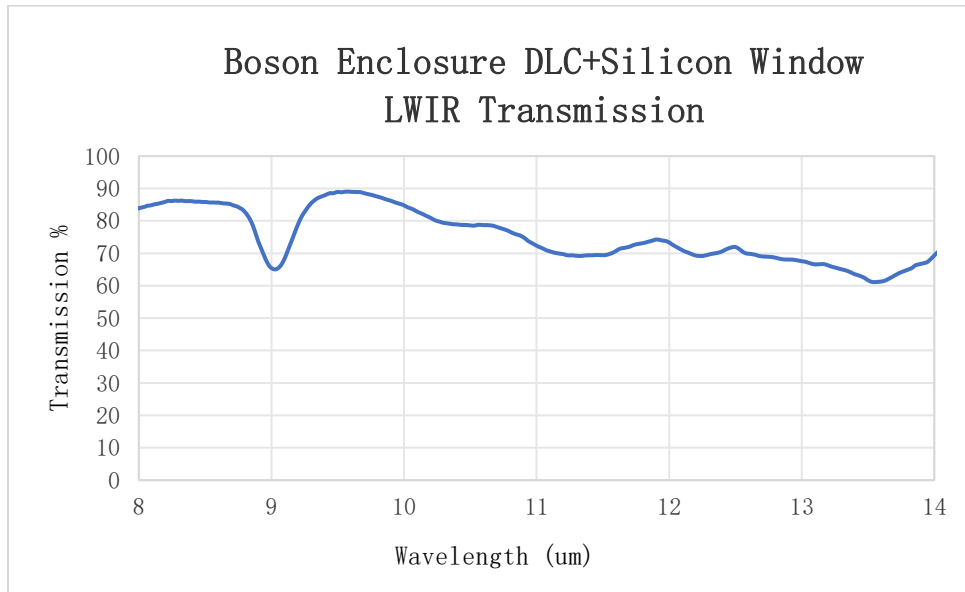

Power Dissipation

From a cold start, the enclosure takes roughly the first 90 minutes to reach thermal steady state, where the FPA stabilizes at approximately **22 °C** above ambient.

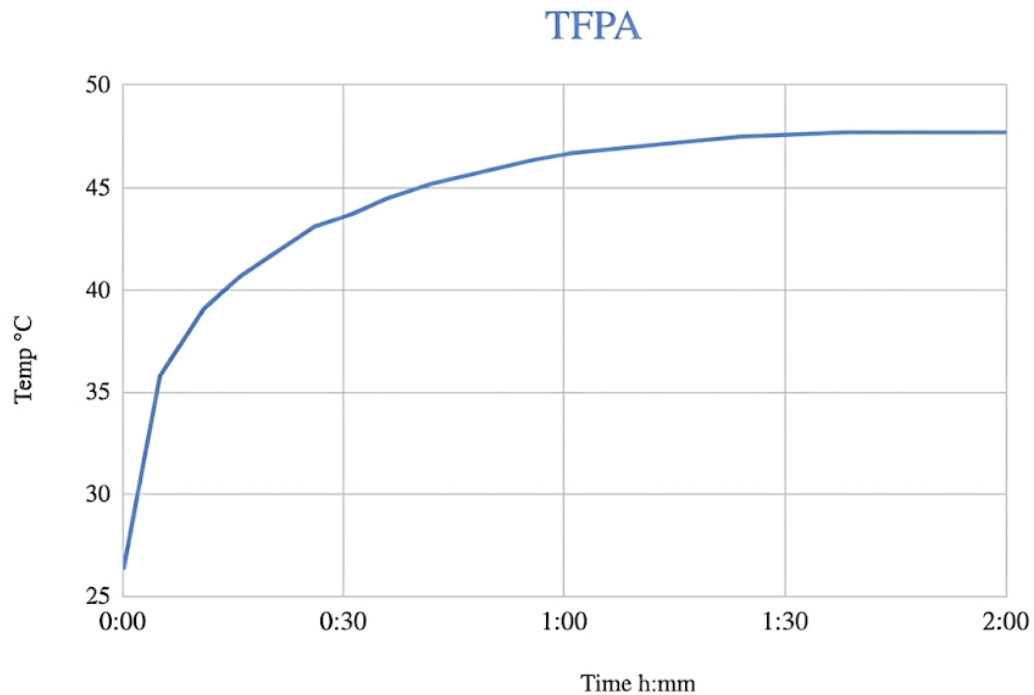

Dimensions

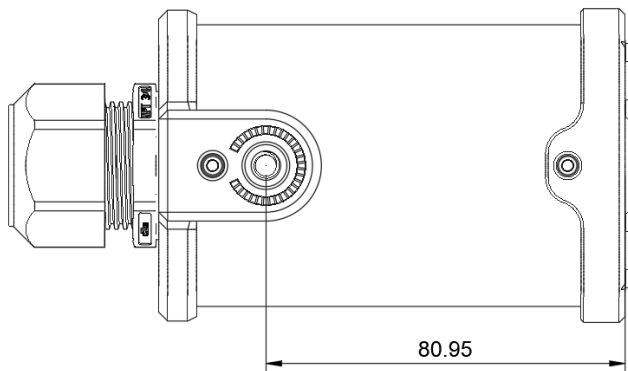
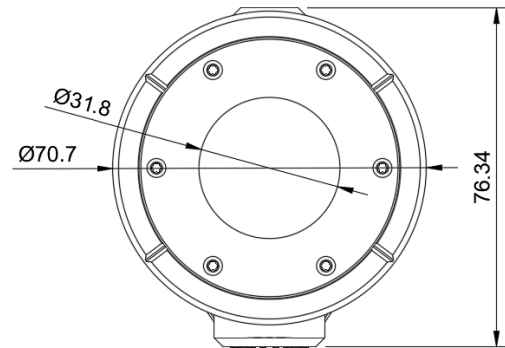
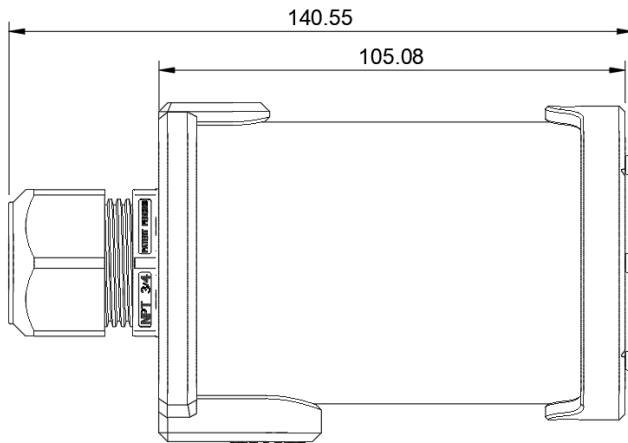

Units: mm
Tol.: ±0.2